

ECONOMY HIGH OUTPUT STRIP

CATALOG NO.	LAMPS	BALLAST	POWER FACTOR	LENGTH	WIDTH	DEPTH	PCS/ CTN	UNIT WT.
4148 S-HO	1-60W	800 MA	High	48	4-5/8	4-3/4	1	14
4248 S-HO	2-60W	800 MA	High	48	4-5/8	4-3/4	1	14
4172 S-HO	1-85W	800 MA	High	72	4-5/8	4-3/4	1	17
4272 S-HO	2-85W	800 MA	High	72	4-5/8	4-3/4	1	17
4196 S-HO	1-110W	800 MA	High	96	4-5/8	4-3/4	1	20
4296 S-HO	2-95W	800 MA	High	96	4-5/8	4-3/4	1	20

TANDEM UNIT - 16 FOOT

4196-2 HO	2-95W	800 MA	High	192	4-5/8	4-3/4	1	32
-----------	-------	--------	------	-----	-------	-------	---	----

- ⓓ Housing and ends are die-formed steel, finished with baked white polyester powder coating.
- ⓓ Snap-on channel covers and ends do not require tools for installation and maintenance.
- ⓓ Combination end plate - channel connector furnished.
- ⓓ High output model--800 mA.
- ⓓ Optional asymmetrical reflectors available.

All H & H Lighting Fixtures are completely wired for 118 volts 60 cycle A.C. operation. Ready for installation. All fixtures bear the I.B.E.W., A. F. of L. and Underwriters Laboratories, Inc. labels.



ECONOMY HIGH OUTPUT

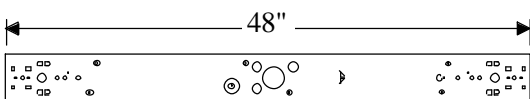
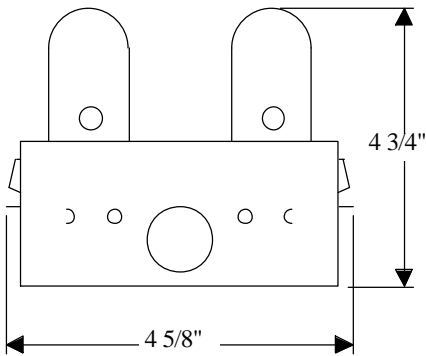
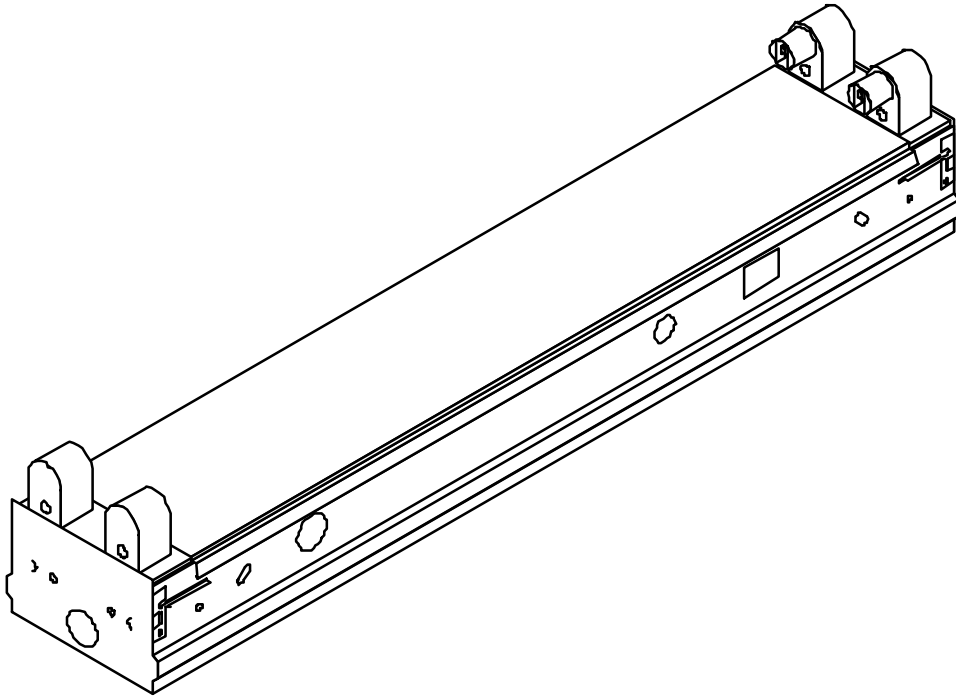

MOUNTING - Complete with knockouts for surface mounting or pendant mounting, individually or in continuous rows. Pendant mounting accessories available on specification. Conduit knockouts are supplied on ends and back.

ELECTRICAL - Furnished standard with UL listed ballasts, for 120 Volt 60 Hz A.C. operation. Other voltages and accessories available. Fixtures bear the I.B.E.W., A.F. of L., and Underwriters' Laboratories, Inc. labels.

APPLICATION - All industrial fixtures are designed for quick, easy installation, either hanging or flush, individually or in continuous rows.

CONSTRUCTION - Wireway and ends die-formed of code gauge steel, finished in automatic bonderizing, rust preventative process, with high reflectivity powder coated baked white enamel. Reflector is removable for easy access to electrical components.